

AV820

Projector Cage (with AV815 Version)



**Anti-Thief/
Security
Solution**



DESCRIPTION

AV820 fully encloses projector in a locked steel cage to prevent thief, as well as recreational damage. it is a security solution for schools, open area, halls to save unnecessary costs and hassles caused by projector thief.

FEATURES

- ✔ Heavy gauge cold-roll steel construction
- ✔ Install and remove without disturbing projector setting
- ✔ Holes patterns provide proper ventilation
- ✔ Security lock with one key access
- ✔ Fits onto AtUS common projector ceiling mount
- ✔ Suitable for projector size up to (W x D x H) 300 x 250 x 100mm

SPECIFICATIONS

Color	Bkck or Silver
Dimension (w x d x h)	407mm x 410mm x 202mm
Weight	5kg

Technical Specifications

	mm	inch
A	407	16.02
B	410	16.15
C	202	7.95
D	300	11.81
E	130	5.12
F	42	1.65
G	362	14.25
H	180	7.09
I	939	36.97
J	689	27.13

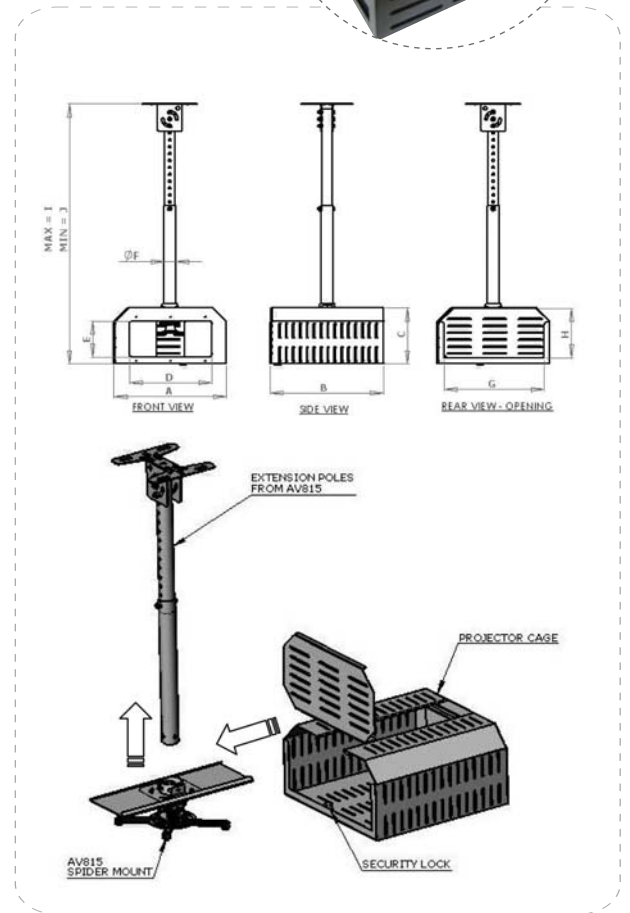

Fix the assembled Top mounting plate onto ceiling (with Projector mounted, not shown), slide the Cage onto the Top Mounting plate.



Cover with Back cover after cable routing and Projector adjustment are done.



Secure with key lock.